

SULLAIR RFE SERIES

50 Hz Refrigerated Dryers



LEGENDARY SULLAIR PRODUCTS

Sullair compressed air solutions have been at the leading edge of rotary screw technology since 1965. The legacy continues as Hitachi Global Air Power—featuring the legendary Sullair product line.

COMPRESSED AIR SOLUTIONS DESIGNED FOR RELIABILITY & DURABILITY

RELIABILITY

Customers who work with Sullair compressors have found intangibles make all the difference—things like trust, confidence and peace of mind. They go to work every day having full faith in their equipment, as well as the knowledge they have access to true compressor experts ready to support them every step of the way.

DURABILITY

Bulletproof. Built to last. However you spin it, Sullair compressors are in it for the long haul, driven by the design of the legendary air end. All over the world, you'll find Sullair compressors that have stood the test of time, running consistently today as they did on day one.

The Hitachi Global Air Power network of engineering and quality experts continues to build next-generation, environment-forward compressed air solutions to meet the demands of today's hard-working customers.

THE IMPORTANCE OF CLEAN, DRY COMPRESSED AIR

A well-designed air treatment system has a number of critical stages, each contributing to the goal of clean, dry air. The following diagram represents a sample of a complete system from start to finish.

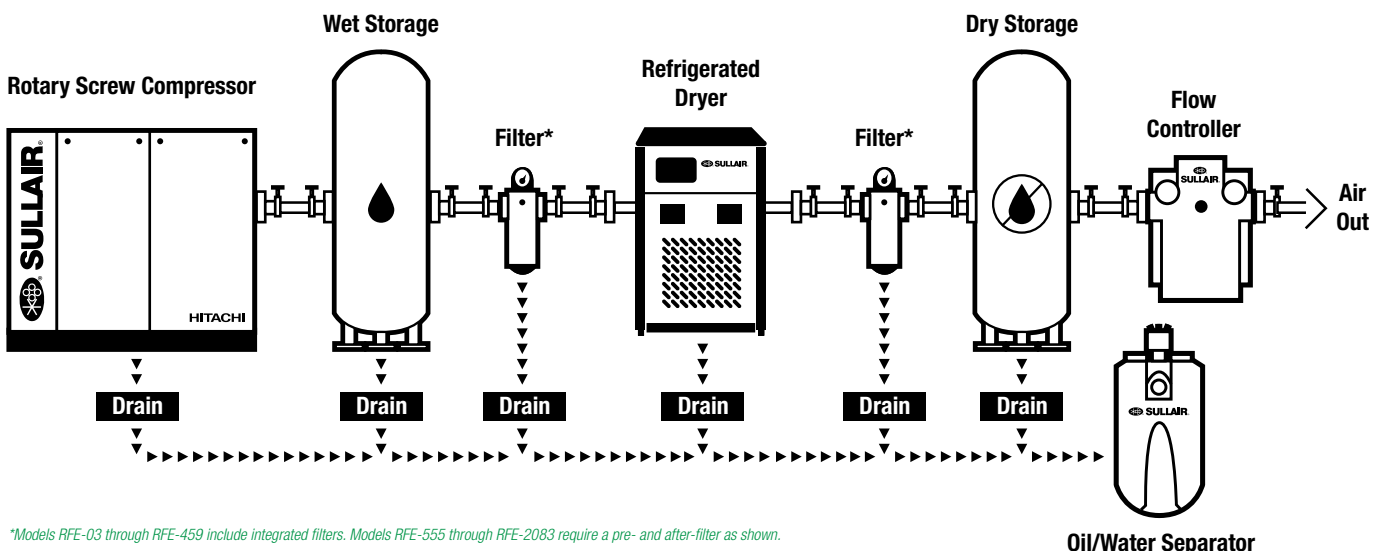

*Models RFE-03 through RFE-459 include integrated filters. Models RFE-555 through RFE-2083 require a pre- and after-filter as shown.

Oil/Water Separator

ADVANCED DESIGN. EFFICIENT PERFORMANCE.

Featuring high-quality engineering in a compact design, the Sullair RF Dryer performs reliably to maximize the quality of your air. Every unit is specially designed according to its flow with the right components to ensure low energy consumption. Other highlights of this durable equipment include a quick start time, efficient operation, and easy access for service and maintenance.

- Digi-pro controller offers one-touch adjustments with digital dew point monitoring, energy-saving mode, maintenance intervals, hour meter and status report. (Available on models RFE-03 through RFE-652)
- ESD3 controller provides economy features and alarm capabilities. (Available on models RFE-847 through RFE-2083)
- **Aluminum Plate Heat Exchanger**
Featuring a state-of-the-art design, this component is standard for all units, and offers some of the industry's best cost savings
 - Very low pressure drop saves compressor power
 - Thin aluminum plate thickness
 - High heat transfer surface area
 - Thick external cylindrical wall offers added strength
 - Water separator optimized for best performance
- **Quick Start and Reaction Times**
 - Provides additional production time
- **Energy Efficiency**
 - Highly energy-efficient R134a refrigerant standard across all models
- **Best-in-class Refrigerant Compressors**
 - Consumes less energy than competitive dryers
 - Scroll compressors — energy efficient and strong against liquid shock — are standard for models RFE-82 through RFE-2083
- **Pressure Switches**
 - Control the condenser's fan motor for energy saving and system operation at desired conditions
- **Safe and Easy Electrical Wiring**
 - There are very few electrical wires inside the refrigerant side of the dryer. Electrical box has an external cover with outside access, so there is no need to open dryer panels for electrical access.
- **Dew Point of 3°C to +10°C Depending on Working Conditions**
- **Sullair Warranty: 2 Years**
- **Electrical Conformance Standards: UL-508A**
- **Compact Design**
 - Suitable for small installation spaces.
 - Two filters integrated into the dryer, which saves piping cost, space, and labor time for technicians and end users.
 - Flexibility and economy during transportation
- **Easy Access**
 - Cooling components easily accessible through screw-free panels and plastic handles

AMBIENT CONSIDERATIONS	
Normal Operating Pressure	6.89 bar
Normal Operating Temperature	35°C
Normal Ambient Temperature	25°C
Maximum Operating Pressure	16 bar
Minimum Operating Pressure	4 bar
Maximum Ambient Temperature	45°C
Minimum Ambient Temperature	4°C
Maximum Operating Temperature	50°C



TECHNICAL SPECIFICATIONS

REGION: EMEA & CIS FREQUENCY: 50 Hz THREADS: BSPT

MODEL	RATED FLOW	STANDARD VOLTAGE	PORT SIZE	INTEGRATED FILTERS	WIDTH		DEPTH		HEIGHT		WEIGHT	
	m ³ /min				in	in	mm	in	mm	in	mm	lbs
RFE-03	0.37	230/1/50	1/2" BSPT	FXF-25 + FXH-25	13.91	353	16.65	423	21.93	557	72	33
RFE-06	0.62	230/1/50	1/2" BSPT	FXF-25 + FXH-25	13.91	353	16.65	423	21.93	557	72	33
RFE-08	0.88	230/1/50	1/2" BSPT	FXF-25 + FXH-25	13.91	353	16.65	423	21.93	557	72	33
RFE-16	1.67	230/1/50	3/4" BSPT	FXF-65 + FXH-65	17.85	453	18.64	473	32.75	832	113	51
RFE-25	2.58	230/1/50	3/4" BSPT	FXF-65 + FXH-65	17.85	453	18.64	473	32.75	832	117	53
RFE-31	3.17	230/1/50	3/4" BSPT	FXF-65 + FXH-65	17.85	453	18.64	473	32.75	832	122	55
RFE-35	3.49	230/1/50	1 1/2" BSPT	FXF-240 + FXH-240	19.84	504	21.81	554	34.40	874	172	78
RFE-51	5.07	230/1/50	1 1/2" BSPT	FXF-240 + FXH-240	19.84	504	21.81	554	34.40	874	183	83
RFE-62	6.26	230/1/50	1 1/2" BSPT	FXF-240 + FXH-240	19.84	504	21.81	554	34.40	874	190	86
RFE-82	8.27	230/1/50	2" BSPT	FXF-475 + FXH-475	25.51	648	26.69	678	45.56	1157.5	354	161
RFE-103	10.39	230/1/50	2" BSPT	FXF-700 + FXH-700	25.51	648	26.69	678	45.56	1157.5	364	165
RFE-155	15.52	230/1/50	2" BSPT	FXF-700 + FXH-700	28.66	728	37.32	948	53.91	1369.5	485	220
RFE-200	20.05	230/1/50	2" BSPT	FXF-700 + FXH-700	28.66	728	37.32	948	53.91	1369.5	507	230
RFE-231	23.16	400/3/50	3" BSPT	FXF-1000 + FXH-1000	31.44	798	37.32	948	57.45	1459.5	595	270
RFE-300	30.02	400/3/50	3" BSPT	FXF-1000 + FXH-1000	31.44	798	37.32	948	57.45	1459.5	629	285
RFE-416	41.77	400/3/50	3" BSPT	FXF-1600 + FXH-1600	30.63	778	45.79	1163	67.81	1722	864	392
RFE-459	46.35	400/3/50	3" BSPT	FXF-1600 + FXH-1600	30.63	778	45.79	1163	67.81	1722	904	410
RFE-555	55.61	400/3/50	DN100	—	33.35	847	55	1397	69.65	1769	1085	492
RFE-652	65.38	400/3/50	DN100	—	33.35	847	55	1397	69.65	1769	1146	520
RFE-847	84.95	400/3/50	DN100	—	42.40	1077	57.76	1467	75.83	1926	1535	696
RFE-975	97.72	400/3/50	DN100	—	42.40	1077	57.76	1467	75.83	1926	1583	718
RFE-1162	116.52	400/3/50	DN150	—	41.81	1062	86.13	2188	75.75	1924	1984	900
RFE-1263	131.56	400/3/50	DN150	—	41.81	1062	86.13	2188	75.75	1924	1984	900
RFE-1500	150.36	400/3/50	DN150	—	47.24	1200	88.46	2247	80.46	2044	3528	1600
RFE-1750	175.42	400/3/50	DN200	—	47.24	1200	88.46	2247	80.46	2044	4116	1867
RFE-2083	208.84	400/3/50	DN200	—	61.02	1550	104.33	2650	82.68	2100	4900	2223

FOR ALL MODELS:

Pressure Drop: <0.2 bar

Max Working Pressure: 16 bar

Max Ambient Temperature: 45°C

Max Inlet Temp: 50°C

CORRECTION FACTORS FOR RFE AIR DRYERS								
Inlet Temperature (°C)	30	35	40	45	50	60	-	-
F1	1.29	1.00	0.92	0.78	0.65	0.45	-	-
Ambient Temperature (°C)	20	25	30	35	40	50	-	-
F2	1.05	1.00	0.98	0.93	0.84	0.70	-	-
Pressure (bar)	4	6	7	8	10	12	14	16
F3	0.80	0.94	1.00	1.04	1.11	1.16	1.22	1.25

For more information, contact your local authorized Sullair distributor.