

# S-energy®

## Encapsulated Rotary Screw Air Compressors

Constant Speed Drives and Variable Speed Drives

11–18 kW | 15–25 hp





## Legendary Sullair Products

Sullair compressed air solutions have been at the leading edge of rotary screw technology since 1965. The legacy continues as Hitachi Global Air Power—featuring the legendary Sullair product line.

### **COMPRESSED AIR SOLUTIONS DESIGNED FOR RELIABILITY & DURABILITY**

#### **RELIABILITY**

Customers who work with Sullair compressors have found intangibles make all the difference—things like trust, confidence and peace of mind. They go to work every day having full faith in their equipment, as well as the knowledge they have access to true compressor experts ready to support them every step of the way.

#### **DURABILITY**

Bulletproof. Built to last. However you spin it, Sullair compressors are in it for the long haul, driven by the design of the legendary air end. All over the world, you'll find Sullair compressors that have stood the test of time, running consistently today as they did on day one.

The Hitachi Global Air Power network of engineering and quality experts continues to build next-generation, environment-forward compressed air solutions to meet the demands of today's hard-working customers.

# S-ENERGY® ENCAPSULATED ROTARY SCREW AIR COMPRESSORS

Sullair compressors provide more performance and efficiency than other compressors in this horsepower range and set new standards in virtually every category.

## FEATURES AND BENEFITS

### Standard Features

- Totally Enclosed Fan Cooled motor (TEFC)
- Low life cycle costs including long-life bearings, rotors and consumable parts
- Less than 2 ppm fluid carryover
- Excellent motor cooling design characteristics for longer motor life
- Sequencing standard
- NEMA 12 standard on the Variable Speed Drive models, NEMA 4 is standard on the Constant Speed Drive models
- 7" Sullair Touch Screen Controller (STS)
- Smallest footprint in its class
- Quietest in its class, as low as 66 dBA
- Numerous unique service features
- Environmental, health and safety design features
- Genuine Sullube® non-varnishing, biodegradable compressor fluid
- Optimalair® air filter provides ten times better filtration than other filters
- Total package filtration optional on Constant Speed Drive, standard on Variable Speed Drive
- AirLinx® remote monitoring ready\*
  - Easy-to-enable remote monitoring of key compressor operation parameters, warnings and alarms to help maximize uptime and efficiency

### Quiet Design

- Integrated air end and motor are mounted on rubber isolators
- Insulated intake and exhaust louvers
- Low-noise fan

*So quiet they can be installed anywhere in your facility.*

### Constant Speed Drive Options

- Cold weather package
- Weather hood
- Other motors and starters
- Total package filtration



\*Learn more about AirLinx

# ENGINEERED FOR EASY MAINTENANCE

Sullair compressors provide reliable performance and efficiency in one of the most compact, robust, maintenance-friendly and quietest compressor packages available.

S-energy Series compressors revolutionize serviceability and optimize efficiency—helping save you time and money.

Standard maintenance can all be performed from one side.



## Sullair Optimizer™ Air-Fluid Separator

- High-efficiency media
- Lower pressure drop reduces power consumption
- Less than 1 ppm carryover reduces cost of make-up fluid

## Fiberglass Fluid Filter

- Coreless, non-metallic design means easy disposal
- 20% more efficient than common cellulose media
- Better filtration helps extend compressor life

## Sullair Optimalair® Air Filter

- Provides the finest inlet filtration in the industry (.4 micron)
- Keeps fluid clean and extends life of internal components
- Reduces pressure drop during operating life, resulting in energy savings

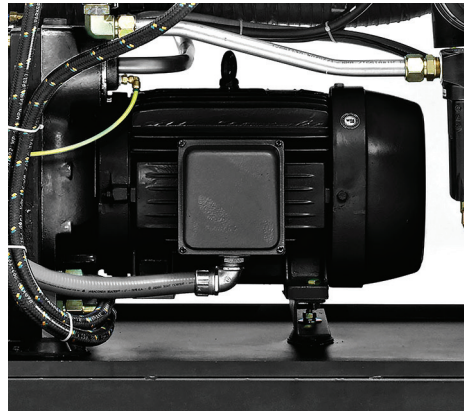

## Sullair Motor Features:

- Slow speed—1800 rpm
- Cast iron construction
- NEMA TEFC design
- Direct coupled/flange mounted
- Most comprehensive warranty in the industry

## Environmental Protection Pan

S-energy units feature a fully sealed environmental protection pan to capture spills that may occur during servicing.

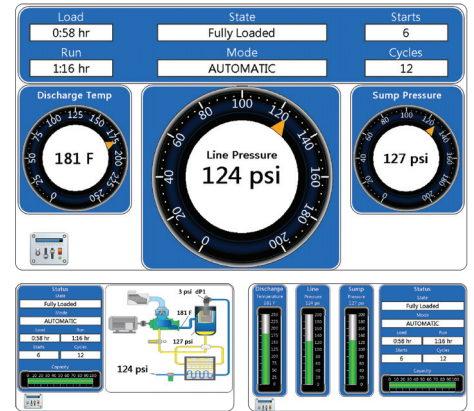

## Sullair Touch Screen Controller (STS)

The Sullair Touch Screen (STS) Controller utilizes a large 7" color screen for easy viewing in any lighting condition.

Menu-driven screens provide easy access to all compressor controls:

- Support for sequencing up to 16 compressors
- More communication capabilities: Ethernet, ModBus RTU and ModBus TCP, Cellular (AirLinx® service)
- Remote access capability via VNC (Virtual Network Computing) protocol
- Start/Stop scheduling with pressure control
- NEMA 4 environmental protection
- Discreet Start and Stop buttons
- Bright operating stats LEDs even when display is dimmed
- Expandable I/O for additional sensor monitoring and output control
- Supports power monitoring
- Trend graphing of operational parameters
- Most controller functions and adjustments via protected controller submenus
- New data download capabilities

### 1. Convenient Separator Element

The separator is conveniently located for easy service. With no tubing to disconnect, leaks are prevented and service time is minimized.

### 2. Sight Glasses

The fluid fill and operating fluid level indicator sight glasses are conveniently located for easy access.

### 3. Electric Solenoid Drain

This Series features an electric solenoid drain with an easy-to-clean strainer that improves reliability. Energy-saving zero loss drains are also available.

### 4. Quick Access to Cooler

With the removal of just a few bolts, the cooler slides out on rails for easy routine cleaning.

### 5. Quick Thermostat Change

To change the thermostat, simply thread the old thermostat out, and the new one in.

### 6. Simplified Filter Change

Changing the fluid and air filters is simpler than ever. The fluid filter is in an inverted position to minimize lubricant loss during filter changes.

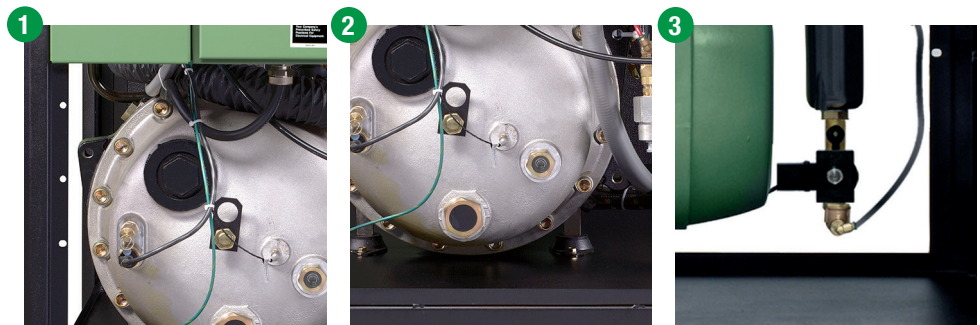
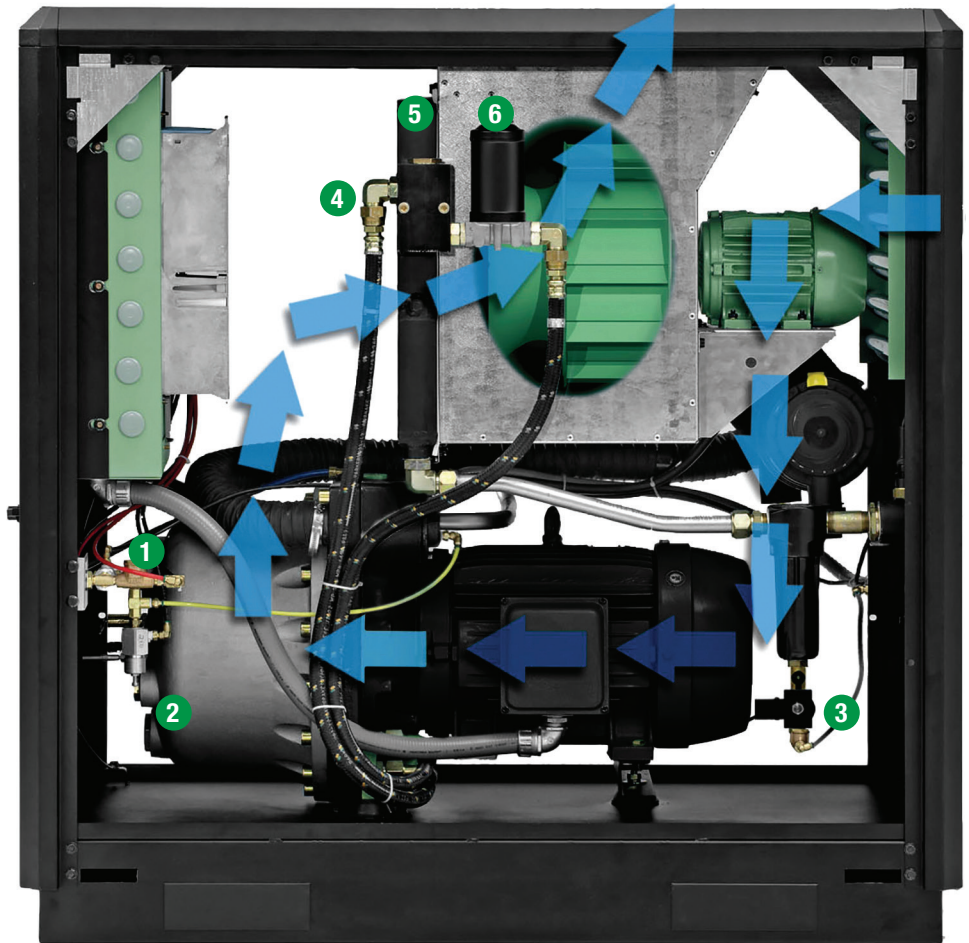

### 10-year Diamond Warranty

Confirming our rugged design and commitment to customer satisfaction, all new Sullair S-energy® stationary air compressors plus select other models (with discharge pressures up to 150 psi) include the exclusive 10-year Diamond Warranty. The comprehensive warranty covers:

- 10 years on the air end
- 5 years on the motor, VSD, air/fluid receiver, oil cooler and aftercooler

*Maintaining the Sullair 10-Year Diamond Warranty requires using Genuine Sullair parts, Sullube®, and participation in the oil sampling program. Restrictions apply.*

# SULLAIR VSD AIR COMPRESSORS

## Sullair compressors with VSD provide:

- Excellent energy savings
- Relief from potential peak demand charges
- Possible utility company rebate
- DC link Choke with 3% Line Reactor included (Model/Voltage Specific)
- Stable system pressure
- Consistent product quality
- Reduced system air leaks
- Reduced storage requirements
- Flexibility for future growth
- Low five-year life cycle cost

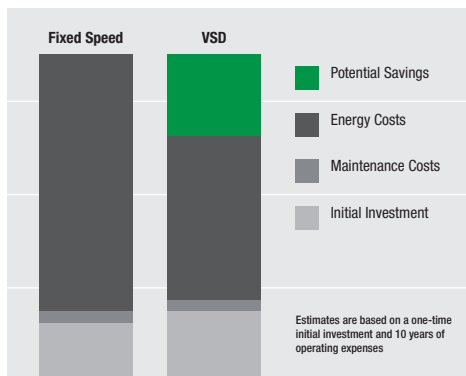

## Your Compressed Air System Can Improve Your Bottom Line

In just ten years, the electrical power cost to operate a standard compressor can be more than six times greater than its purchase price.

## Total Compressor Flexibility

Sullair VSD compressors provide the flexibility to vary both capacity and pressure. This flexibility makes it possible to “grow” your air system without adding more compressors.

## PART-LOAD PERFORMANCE ASSESSMENT

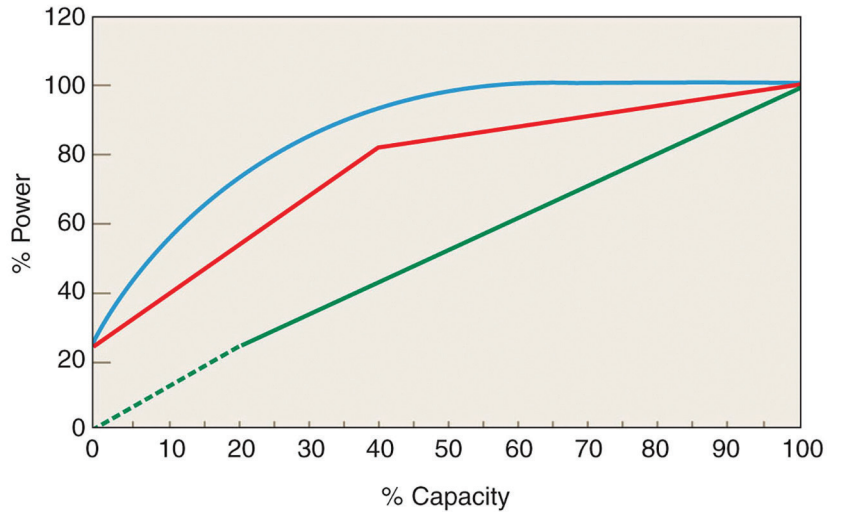

- Single-Stage Lubricated Load/Unload (The graph represents one gallon of storage per cfm.)
- Single-Stage Lubricated Inlet Modulation with Blowdown
- Single-Stage Lubricated Variable Speed



Reference: *Compressed Air and Gas Handbook, 6th Edition, pages 221-224.*

## Variable Speed Drive is the Superior Alternative

The chart above is a representation of nominal control systems for generic comparative purposes. A detailed and accurate comparison of specific compressor models is available from your Sullair representative or authorized distributor.

### Standard Compressors

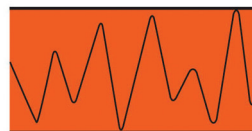

### Sullair VSD Compressors



## Stable System Pressure Improves the Consistency of Processes to Reduce Product Rejects

- Lowers air system leaks
- Reduces system storage requirements
- Provides increased energy savings to increase profits

## Soft Start is Standard with Unlimited Starts and Stops

- No need for Wye Delta and other soft starters
- No need to control the number of hot or cold starts
- Unlimited starts and stops save electrical costs
- Avoids high electrical current at start-up

## VSD Avoids Potential Peak Demand Charges

VSD compressors provide the highest power factor over the entire frequency range, often avoiding utility company penalties.

# SULLAIR STATIONARY AIR POWER SYSTEMS

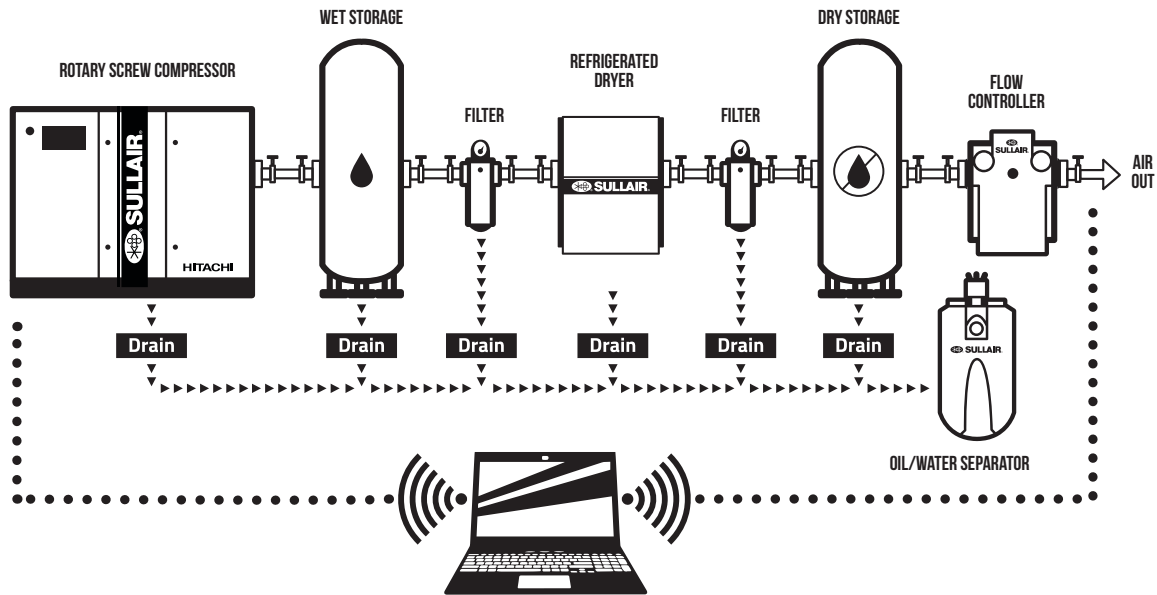

Hitachi Global Air Power offers total compressed air systems to help compressed air users reduce energy costs and improve productivity by analyzing, managing and controlling their compressed air systems.

Sullair air systems include: plant air audits, energy efficient products, compressed air system controls, equipment to monitor and manage systems, air distribution products, and after-purchase support.

Each component of the system is carefully matched for capacity and pressure to provide reliable performance and energy efficiency.

## The system includes:

- Rotary screw compressor
- Wet storage
- Refrigerated dryer or desiccant dryer
- Filters to meet your requirement
- Dry storage
- Flow controller
- Drains
- Oil/water separator

## Solutions To Help Reduce Life Cycle Costs



- Equipment
- Maintenance
- Electricity

## Air Compressor Life Cycle Costs

According to *Best Practices for Compressed Air Systems, Compressed Air Challenge* [Second Edition, 2007] energy costs now represent 82% of the total operating expenses. Energy savings from Sullair S-energy® compressors can significantly reduce life cycle costs.

## S-energy compressors can significantly reduce operating and energy costs over the entire compressor life cycle:

- Proven Sullair air end with a low restriction inlet valve
- High efficiency fan
- Low pressure drop air-fluid separation system to prevent energy loss

## Sullair designs deliver cost savings for the life of the product.

### Improved air filtration translates into:

- Extended separator life
- Improved fluid filter life
- Less lubricant contamination

## To reduce fluid disposal costs, S-energy compressors are factory-filled with biodegradable Genuine Sullube® fluid.

- Protects and cleans (no varnish)
- Controls operating temperatures
- Optimal viscosity
- Environmentally friendly
- Reduces fluid loss
  - High flash point (505°F/263°C)

# TECHNICAL SPECIFICATIONS

60HZ MOTOR FREQUENCY	MOTOR		CONSTANT SPEED DRIVE PERFORMANCE FULL-LOAD CAPACITIES **								WEIGHT		DISCHARGE CONNECTION	dBA†
	Model*	hp	kW	100 psi cfm	7 bar m³/min	125 psi cfm	8.6 bar m³/min	150 psi cfm	10.3 bar m³/min	175 psi cfm	12.1 bar m³/min	lbs		
1100e	15	11	68.5	1.93	60.2	1.70	-	-	43.7	1.23	1044	474	1½" NPT	66
1500e	20	14.7	-	-	79.2	2.24	-	-	61.5	1.74	1098	498	1½" NPT	66.5
1800e	25	18.4	-	-	99.3	2.81	-	-	78.5	2.22	1122	509	1½" NPT	67

60HZ MOTOR FREQUENCY	MOTOR		VARIABLE SPEED DRIVE PERFORMANCE FULL-LOAD CAPACITIES **								WEIGHT		DISCHARGE CONNECTION	dBA†
	Model*	hp	kW	100 psi cfm	7 bar m³/min	125 psi cfm	8.6 bar m³/min	150 psi cfm	10.3 bar m³/min	175 psi cfm	12.1 bar m³/min	lbs		
1100eV	15	11	69.2	1.95	59.1	1.67	50.6	1.43	46.4	1.31	1078	489	1½" NPT	66
1500eV	20	14.7	90.9	2.57	80.9	2.29	69.6	1.97	64.8	1.83	1132	513	1½" NPT	66.5
1800eV	25	18.4	107.8	3.05	99.8	2.82	90.2	2.55	81.3	2.30	1156	524	1½" NPT	67

50HZ MOTOR FREQUENCY	MOTOR		CONSTANT SPEED DRIVE PERFORMANCE FULL-LOAD CAPACITIES **								WEIGHT		DISCHARGE CONNECTION	dBA†
	Model*	hp	kW	100 psi cfm	7 bar m³/min	125 psi cfm	8.6 bar m³/min	150 psi cfm	10.3 bar m³/min	175 psi cfm	12.1 bar m³/min	lbs		
1100e	11	15	66.5	1.88	-	-	48.8	1.38	36.1	1.02	1044	474	1½" NPT	66
1500e	14.7	20	83.8	2.37	-	-	64.8	1.83	60.6	1.72	1098	498	1½" NPT	66.5
1800e	18.4	25	98.3	2.78	-	-	81.7	2.31	76.4	2.16	1122	509	1½" NPT	67

50HZ MOTOR FREQUENCY	MOTOR		VARIABLE SPEED DRIVE PERFORMANCE FULL-LOAD CAPACITIES **								WEIGHT		DISCHARGE CONNECTION	dBA†
	Model*	hp	kW	100 psi cfm	7 bar m³/min	125 psi cfm	8.6 bar m³/min	150 psi cfm	10.3 bar m³/min	175 psi cfm	12.1 bar m³/min	lbs		
1100eV	11	15	66.0	1.87	56.5	1.60	48.0	1.37	44.5	1.26	1078	489	1½" NPT	66
1500eV	14.7	20	86.6	2.49	77.3	2.19	67.8	1.92	58.9	1.67	1132	513	1½" NPT	66.5

DIMENSIONS	LENGTH		WIDTH		WEIGHT	
	in	mm	in	mm	lbs	kg
Model*						
1100e, 1500e, 1800e, 1100eV, 1500eV, 1800eV	53.2	1351	31.5	800	1351	532

\* Model Variations: V = Variable Speed Drive; e = Encapsulated

\*\* Capacity per CAGI / PNEURO P PN2CPTC2 (Annex C to ISO 1217)

Moisture Drain Connection at ¼" NPT

† dBA at 1 meter

Information and data are subject to change without notice.

For more information, contact your local authorized Sullair distributor.